

INSTRUCTION MANUAL

SG-340 Manual Surface Grinder (240V) 340 x 170mm



G203

CONTENTS

Specifications.....	1
Safety Instructions.....	1
Operating Instructions	6
Test Certification	20
Packing List	25

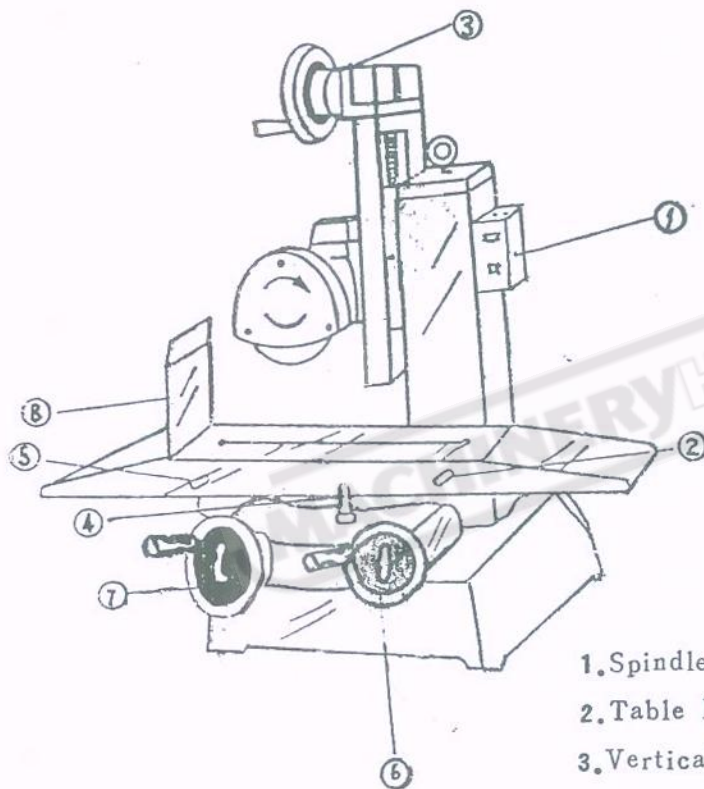

Picture 1

1. Spindle "Start-Stop" Buttons.
2. Table Dog.
3. Vertical Adjustment Handwheel.
4. Table Dog Stop.
5. Table Dog.
6. Table Travel Handwheel.
7. Cross Feed Handwheel.
8. Shield Plate.

SPECIFICATIONS

Motor:

240V olts

50 Hz

3.6 amps

3/4 Hp

Single phase

2800 RPM

Grinding:

180 outside diameter x 32 inside diameter x 13 thick wheel

340 maximum longitudinal travel

170 maximum cross travel

152 x 304 work table

210 maximum work height

13 x 390 T-slots

0.02 elevation graduations

0.02 cross graduations

SAVE THIS MANUAL

You will need this manual for the safety instructions, assembly instructions, operating procedures, parts list, and diagram. Put them in a safe, dry place for future reference.

IMPORTANT SAFETY PRECAUTIONS

WARNING: When using electric tools, machines or equipment, basic safety precautions should always be followed to reduce the risk of fire, electric shock, and personal injury.

READ ALL INSTRUCTIONS BEFORE USING THIS TOOL

1. **KEEP WORK AREA CLEAN.** Cluttered areas invite injuries.
2. **CONSIDER WORK AREA CONDITIONS.** Don't use machines or power tools in damp, wet, or poorly lit locations. Don't expose to rain. Keep work area well lit. Don't use tools in the presence of flammable gases or liquids.

3. KEEP CHILDREN AWAY. All children should be kept away from the work area. Don't let them handle machines, tools or extension cords.
4. STORE IDLE EQUIPMENT. When not in use, tools should be stored in a dry location to inhibit rust and locked up. If possible, also store in an area out-of-reach of children.
5. DON'T FORCE THE MACHINE OR TOOL. It will do the job better and more safely at the rate for which it was intended.
6. USE THE RIGHT TOOL. Don't force a small tool or attachment to do the work of a larger industrial tool. Don't use a tool for a purpose for which it was not intended.
7. DRESS PROPERLY. Don't wear loose clothing or jewelry. They can be caught in moving parts. protective, electrically non-conductive gloves and non-skid footwear are recommended when working. wear protective hair covering to contain long hair, preventing it from getting caught in machinery.
8. USE EYE AND EAR PROTECTION. Use a full face mask if the work you're doing produces metal filings, dust or wood chips. Goggles are acceptable in other situations. Wear a clean dust mask if the work creates a lot of fine or coarse dust. When operating for extended periods of time, use approved ear protection.
9. DON'T ABUSE THE POWER CORD. Do not yank it to disconnect it from receptacle. Do not move bench-mounted or floor-standing machines with the power cord in the outlet. Keep cord away from heat, oil, and sharp edges.
10. SECURE WORK. Use clamps or a vise to hold the work if possible. It's safer than using your hands and it frees both hands to operate the tool.
11. DON'T OVERREACH. Keep proper footing and balance at all times. Do not reach over or across machines which are running.
12. MAINTAIN TOOLS WITH CARE. Keep tools sharp and clean for better and safer performance. Follow instructions for lubricating and changing accessories. Inspect tool cords periodically and if damaged, have them repaired by an authorized service facility. Keep handles dry, clean, and free from oil and grease.

13. DISCONNECT POWER. Unplug when not in use, before servicing, and when changing accessories such as blades, bits, and cutters.
14. REMOVE ADJUSTING KEYS AND WRENCHES. Make it a habit to check that keys and adjusting wrenches are removed from the tool or machine work surface before plugging it in.
15. AVOID UNINTENTIONAL STARTING. Be sure the switch is in the OFF position when not in use and before plugging in.
16. OUTDOOR EXTENSION CORDS. When the equipment is operated outdoors, use only extension cords intended for outside use. See chart under "Extension Cords" for the proper AWG rating depending upon length of the cord.
17. STAY ALERT. Watch what you are doing, use common sense. Don't operate any tool when you are tired.
18. CHECK DAMAGED PARTS. Before using any tool, any part that is damaged should be carefully checked to determine that it will operate properly and perform its intended function. Check for alignment of moving parts, binding of moving parts, breakage of parts, mounting, and other conditions that may affect its operation. Any part that is damaged should be properly repaired or replaced by an authorized service center unless otherwise indicated elsewhere in the instruction manual. Have defective switches replaced by an authorized service center. Don't use the tool if switch does not turn on and off properly.
19. GUARD AGAINST ELECTRIC SHOCK. Prevent body contact with grounded surfaces; pipes, radiators, ranges, and refrigerator enclosures.
20. REPLACEMENT PARTS AND ACCESSORIES. When servicing, use only identical replacement parts. Only use accessories intended for use with this tool.
21. DONOT OPERATETOOL IF UNDER THE INFLUENCE OF ALCOHOL OR DRUGS. Read warning labels on prescriptions to determine if your judgment or reflexes are impaired while taking drugs. If there is any doubt, do not operate machine.
22. KEEP GUARDS IN PLACE. All guards and fences need to be in proper working order and alignment. Check before every use.

23. NEVER STAND ON TOOL. If tool is tipped over or if blades or cutters are accidentally contacted, serious injury could result.
24. NEVER LEAVE TOOL RUNNING UNATTENDED. Always turn off power. Do not leave tool until it comes to a complete stop.
25. DIRECTION OF FEED. Only feed stock into a blade or cutter against the direction of its rotation.

GROUNDING INSTRUCTIONS

Check to see if your tool has a two or three-prong plug. If your tool has a two-prong plug, you may proceed to the voltage warning, if your tool has a three-prong, please continue reading the following precautions and instructions.

1. This machine has a three-prong plug, the third (round) prong being the ground. Plug the machine's cord only into a three-prong receptacle. Don't attempt to defeat the protection the ground wire provides by cutting off the round prong.

2. If a three-prong receptacle is not available, you may use an adapter, but you must then connect the green ear on the adapter to the outlet. Unscrew the center screw of the outlet cover and put the screw through the green ear. Plug the adapter's two prongs into the outlet, and replace the center screw. Now plug the machine into the adapter.

VOLTAGE WARNING

Before connecting the tool to a power source (receptacle outlet, etc.) be sure the voltage supplied is about the same as that specified on the nameplate of the tool. If one says 120v and the other says 110v then there will be no complications. Never try to plug a 120V tool into a 240v outlet or the other way around. The plug and outlet have completely different shapes. This is because a power source with a voltage greater than that specified on the tool can result in a SERIOUS INJURY to the user— as well as damage to the tool. If in doubt, DO NOT PLUG IN THE TOOL. Using a power source with voltage (120v) less than the nameplate rating (240v) is harmful to the motor.

INSTALLING OR RELOCATING THE MACHINE

When lifting or moving the machine it is recommended that a rope be rigged as shown in Fig. 2. place wooden blocks or protective material between the rope and the machine wherever the rope is liable to damage it.

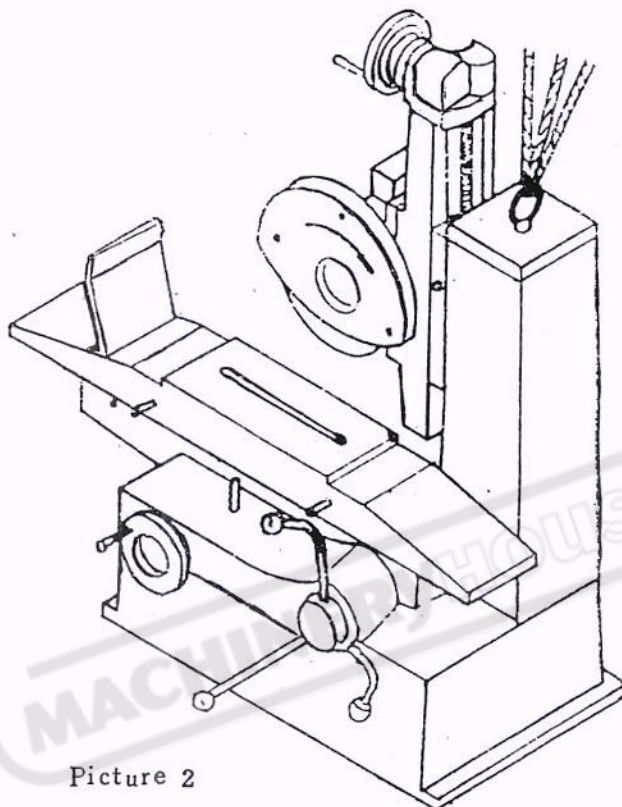

Picture 2

If available, a fork-lift should be used to move the machine. The base of the crate is designed for such operations, if possible leave the grinder bolted to it until you have it in position.

CAUTION: do not push on the upright when moving the machine unless the rods and strap used during shipping are in place. The upright is a sliding mechanism held on by its own weight and the cross feed screw. Considerable damage can be caused to the cross feed screw if the upright is tilted excessively.

After the machine has been installed, first loosen the bolt behind the upright (referring to the warning plate) to keep the balance block travelling freely. Before loosening the bolt, do not move the handwheel in order to prevent the chain from breaking.

The machine should be located on a level foundation or floor, a solid vibrationless foundation is essential to produce the finest finishes. If the machine must be set on a wooden floor, locate it over a beam or other floor support to reduce vibration. In the case where floor vibration is unavoidable, set the machine on a vibration absorbing pad.

If the customer does not buy the stand, he must Prepare a strong base himself, pay much more attention to make a square hole whose length is 150 mm, width is 150 mm and depth is not less than 110 mm to make the balance block travel vertically. picture 3 installing. picture 4 the vertical view of the stand (the dimension is only for reference).

picture 5 the instalment of the stand.

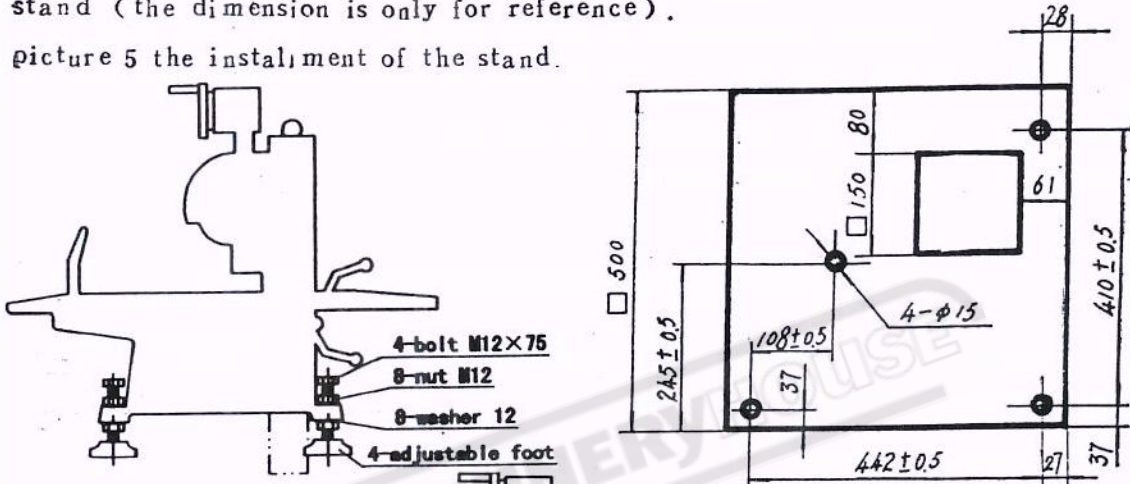

Picture 3

Picture 4

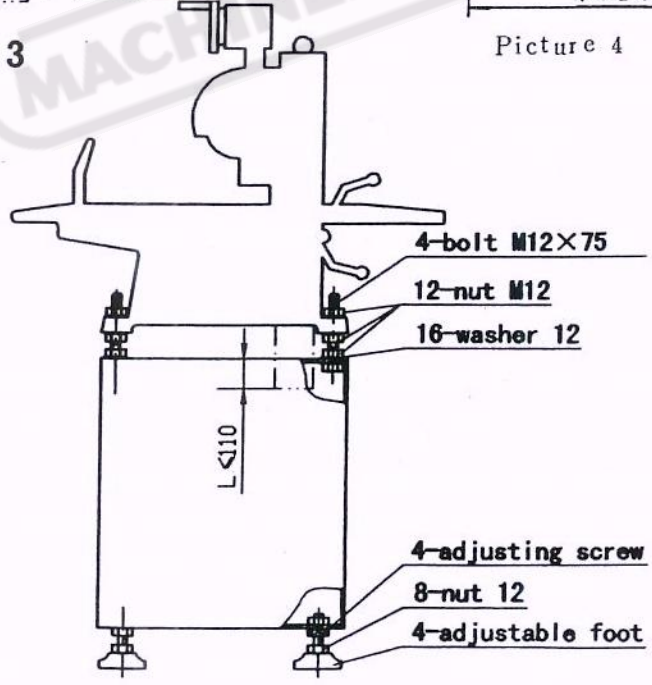

Picture 5

with the machine in position, test the surface of the table, both longitudinal and cross with a precision spirit level and true by placing shims under low corners. Make sure that all four corners are supported, then tighten all lag screws and test the level of the table surface again in both directions—readjust if necessary.

CONNECTING POWER: the machine should be connected to a power line and properly grounded. The lines from the power source should be connected to the magnetic starter (mounted on the right hand of the machine).

CHECK MOTOR ROTATION: Press the button to "start" and observe the spindle rotation. The spindle should rotate clockwise as seen from the front of the machine. If the direction of the wires is counter clockwise, switch the two wires at the motor.

STEP UP ADJUSTMENTS AND OPERATING CONTROLS

WHEEL SPEED: when the spindle is driven by a 50Hz direct drive motor, the full load speed is 2800 RPM using a 180 diameter.13 thick

WHEEL GUARD:

The wheel guard is a one-piece cover on the front. It is held closed with three hexagon head cap screws. Before removing the wheel, you should first take out the screws, then remove the wheel guard to mount and change the wheel.

CARE AND USE OF GRINDING WHEELS

SELECTING THE WHEEL: To produce the desired quality of work in the shortest time, care is necessary in choosing which wheel is best for a particular job. The lower the grit number on the wheel the more material will be removed, higher grit numbers provide finer finishes.

MOUNTING WHEELS: One general-purpose grinding wheel and one wheel sleeve are furnished with the machine. When additional wheels are used, extra wheel sleeves should be purchased so that each wheel can be kept on its own sleeve. This will aid in maintaining wheel concentricity, speed the wheel changing process, and require a minimum of mount truing.

The wheel should fit easily on the wheel sleeve, yet not loosely, for if it is too loose it cannot be centered accurately and will become out of balance. Do not wrap a wheel with paper or other material to fit the sleeve when the hole is too large. If this is the case, either recase the core or discard the wheel.

A wheel that fits too tightly may crack if forced on the sleeve. If the hole is a little undersized it can easily be scraped out.

WARNING: Before mounting a wheel, balance on one finger, then lightly tap the edge of the wheel and listen for a clear ringing sound. A wheel that does not ring is probably cracked and should not be used.

The wheel is held in place with a collar and a lock nut. The outer lock nut is mounted to the spindle. The inner collar consists of a steel disc which is keyed to the wheel to prevent it from turning and loosening the clamping nut.

Most of the wheels used on this machine have blotting paper on each side to equalize clamping pressure. If this is not present, equalize pressure by inserting cardboard or rubber washers.

Using the pin wrench (included) tighten the clamping nut to hold the wheel firmly in place on the sleeve. Excessive pressure may crack the wheel, do not overtighten.

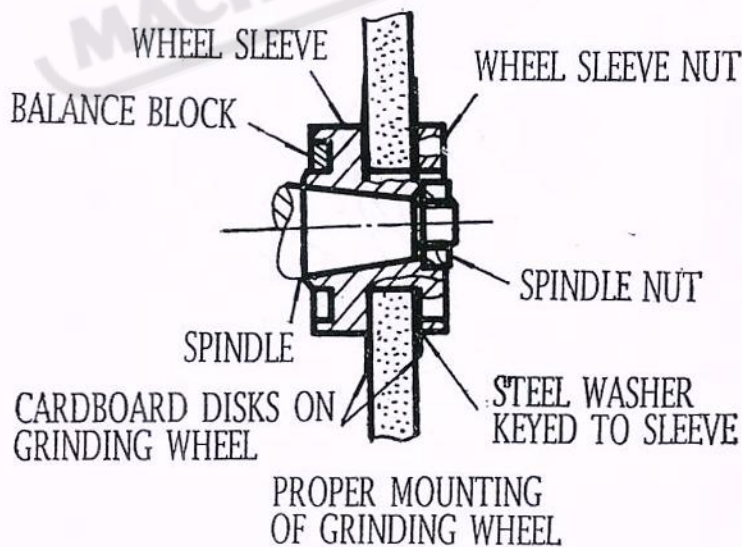

Picture 6

CHANGING WHEELS: To avoid any chance of cracking the wheel or damaging the spindle bearings, remove the wheel sleeve from the spindle using the spindle lock wrench and adjustable pin wrench (included) take off the spindle nut (Note this nut is left-hand threaded). Next thread the outer portion of the wheel sleeve puller into the wheel sleeve and tighten the inner screw against the spindle, this loosens the wheel without harmful jarring.

Before putting the wheel on the spindle, make sure that both the wheel sleeve hole and spindle end are clean. Next slip the sleeve onto the spindle, tighten the clamping nut.

BALANCING WHEEL, It is essential that the wheel run true, without vibration. Grinding wheels are balanced by the manufacturer, and in the case of the types of wheels used by this machine, should not require attention other than truing. A wheel that runs badly out of balance after truing should be discarded or returned to the wheel manufacturer.

WHEEL TRUING, Attach the truing fixture (included) to the table. The truing diamond (included) may be applied to the very bottom of the wheel as shown. To prevent gouging, the center line of the diamond tool should point past the center of the wheel in the direction the wheel turns.

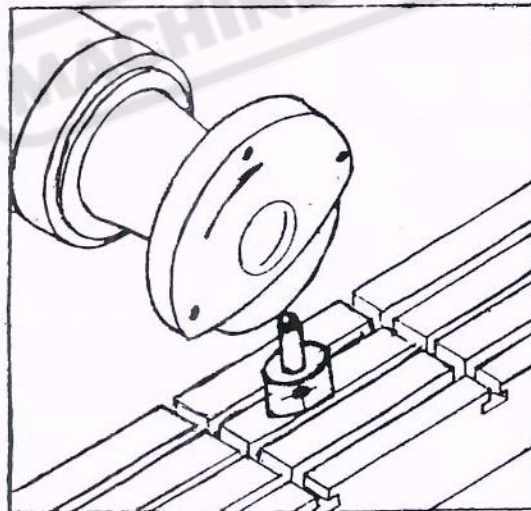

Picture 7

The wheel should be trued each time it is put on the spindle, and whenever it becomes loaded, dull, or glazed. Pass the diamond across the wheel, with a slow, steady manual cross feed, making sure to avoid any longitudinal movement of the table.

In truing the wheel for rough grinding, take a cut about 0.02 mm deep in one pass of the diamond wheel and finish with a second cut at 0.02 mm deep. If the wheel is to be used for fine cuts make four or five cuts removing 0.02 mm material each time. Then pass the diamond across the wheel once or twice without further advancing the wheel. (The figures stated are approximate and may be varied for desired results).

OPERATION OF THE OIL PUMP

1. This machine tool is lubricated automatically by a hand-operated piston oil pump. when the handle of the pump is pulled out, it will return slowly to its original position and concurrently supply oil. You can repeat the above operation to supply oil again.
2. Clean lubricating oil (30-40 cst) is needed for the pump.
3. Attention: The handle of the oil pump can only be pulled outward and can never be pushed inward.

Otherwise, the measuring part in the tube will be damaged.

TYPICAL OPERATION

A representation of a typical production job: Grinding thirty pieces with one loading of a magnetic type chuck.



Picture 8

Slot grinding; Movable wheel slide contributes to excellent results.

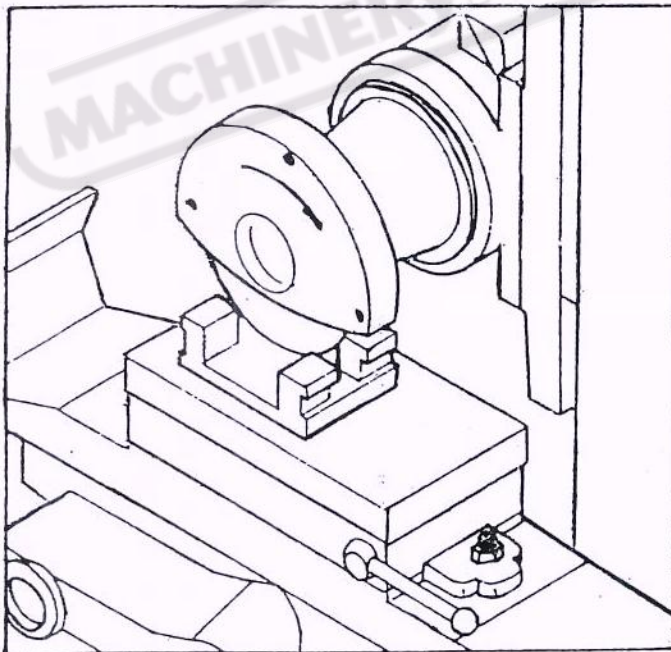

Picture 9

ADDITIONAL EQUIPMENT

Magnetic chucks and precision grinding vises (or machinists vises) can be purchased separately.

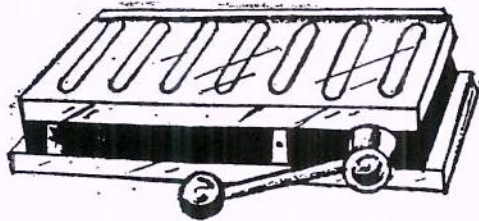

Picture 10

Permanent Magnet Chuck

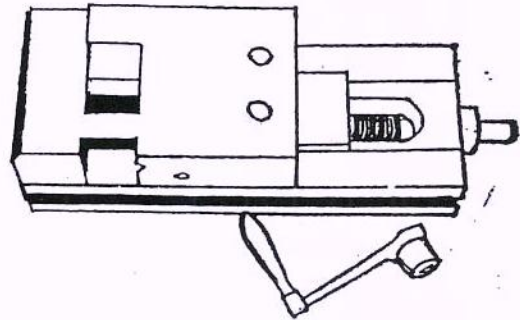

Picture 11

Precision Grinding Vise

Neither chucks nor vises should be exposed to excessive heat, shocks, or blows. Chuck surfaces should be free from pits and scratches.

MAGNETIC CHUCKS:

Magnetic chucks provide quick, easy means of holding a variety of ferrous work pieces. A lever usually controls whether the magnetism is on or off. Because the chuck uses no electricity, it may be left on for as long as desired without heating.

For the greatest accuracy in grinding work parallel, the top surface of the chuck should be ground each time the chuck is mounted to the machine. Turn on the chuck before grinding, and remove only the minimum amount of material required. Grind the entire surface of the chuck.

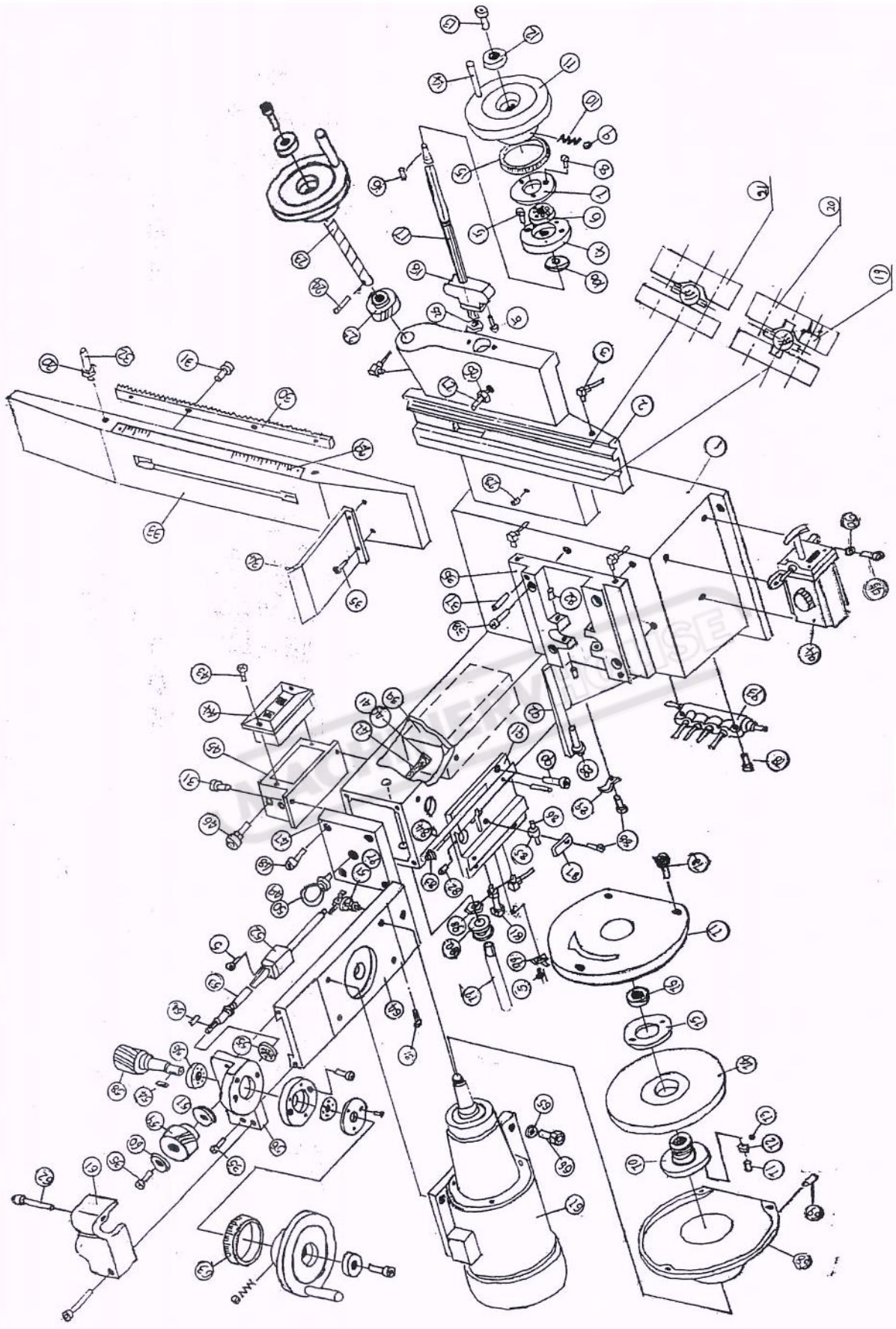

PARTS LIST				
REF No.	PARTS No.	PARTS NAME	MATERIAL & SPEC.	AMT USED
1	MJ7115.1-01	Base	HT200	1
2	MJ7115.1-03	Dovetail groove	HT150	1
3		Oil pipe joint		5
4	MJ7115.1-31 1-31a	Elevating bearing block Longitudinal Bearing block	45	1/1
5	GB70-85	Socket head cap screw	M5×16	10
6	GB276-84	Bearing	60202	2
7	MJ7115.1-29	Locking washer	A3	2
8	GB819-85	Round head plus screw	M5×10	6
9	GB308-84	Steel ball	∅6	2
10	MJ7115.1-30	Spring	65Mn	2
11	MJ7115.1-34 1-34a	Handwheel	HT150	2/1
12	MJ7115.1-33	Screw seat	HT150	3
13	GB70-85	Socket head cap screw	M6×16	3
14	GB4141.5-84	Handle	M8×63	3
15	MJ7115.1-38a	Dial	A3	1
16	GB1096-79	key	4×4×16	2
17	MJ7115.1-36a	Longitudinal feed screw	45	1
18	MJ7115.1-37a	Nut	ZnS6-6-3	1
19	GB70-85	Socket head cap screw	M5×16	16
20	MJ7115A.1-05	Rolling guide	Model A	1
21	MJ7115A.1-05	Rolling guide	Model B	1
23	MJ7115.1-43a	Cross feed shaft	45	1
24	GB117-86	Taper pin	5×30	1

PARTS LIST				
REF No.	PARTS No.	PARTS NAME	MATERIAL & SPEC.	AMT USED
25	MJ7115.1-42	Cross feed helical gear	45	1
26	GB6170-86	Nut	M10	2
27	MJ7115.1-45Q	Limited lever	A3	1
28	GB1155-74	Oil cup	8	1
29	MJ7115.1-40	Surveyer's rod	AL	1
30	MJ7115.1-06	Rack	45	1
31	GB70-85	Socket head cap screw	M6×12	1
32	MJ7115.1-41	Limited lever	A3	2
33	MJ7115.1-04	Work bench	HT150	1
34	MJ7115.1-39	Fender	HT150	1
35	GB70-85	Socket head cap screw	M6×20	5
36	MJ7115.1-02	Longitudinal feed dovetail groove	HT150	1
37	GB118-86	taper pin	6×40	4
38	GB70-85	Socket head cap screw	M10×35	4
39	MJ7115.1-12	Balance block	HT150	1
40	MJ7115.1-13	Fixing screw	45	1
41	GB5976-86	Steel cable clip	Y6	1
42		Steel cable	Ø3	
43	GB819-85	Cross recessed pan screw	M5×6	2
44		Switch	30A/250V	1
45	MJ7115.1-20	Cwitch box	A3	1
46		Pilot lamp		2
47	MJ7115.1-22	Cover	HT150	1
48	GB70-85	Socket head cap screw	M10×25	4

PARTS LIST				
REF No	PARTS No.	PARTS NAME	MATERIAL & SPEC.	AMT USED
49	GB6170-86	Nut	M16	1
50	GB825-88	Lifting ring	M16	1
51	MJ7115.1-07	Fixing screw	45	1
52	MJ7115.1-19a	Elevating nut	ZQSn6-6-3	1
53	MJ7115.1-23a	Elevating screw	45	1
54	GB1096-79	Key	4×4×20	2
55	GB276-84	Ball bearing	1000902	2
56	MJ7115.1-24	Seat	HT150	1
57	GB301-84	Thrust bearing	8102	1
58	MJ7115.1-26	Gear shaft	45	1
59	MJ7115.1-25	Gear	45	1
60	MJ7115.1-27	Washer	A3	1
61	MJ7115.1-28	Cover	HT150	1
62	GB70-85	Socket head cap screw	M6×55	2
63	MJ7115.1-33	Dial	A3	1
64	MJ7115.1-14	Elevating dovetail groove	HT150	1
65	GB97.1-85	plain washer	10	4
66	GB5783-86	Hexagon head bolts	M10×35	4
67		Motor	3/4HP	1
68	MJ7115.2-05	Rear cover of grinder	HT150	1
69	GB80-85	Hexagon Socket screw with cup point	M8×10	1
70	MJ7115.2-04	Slide	45	1
71	GB73-85	Slotted set screw with flat point	M6×6	3
72	MJ7115.2-06	Shifter	A3	3

PARTS LIST				
REF No	PARTS No.	PARTS NAME	MATERIAL & SPEC.	AMT USED
73	GB308-84	Steel ball	Ø4	3
74		Grinding wheel	180 × 31.75 × 13	1
75	MJ7115.2-03	Collar	45	1
76	MJ7115.2-02	Round nut with holes in one face	M16 × 1.5	1
77	MJ7115.2-01	Front cover of grinder	HT150	1
78	GB70-85	Socket head cap screw	M6 × 25	3
79	MJ7115.1-15	Pulley shaft	45	1
80	MJ7115.1-16	Pulley	A3	1
81	GB5783-86	Hexagon head bolts	M8 × 60	1
82	GB80-85	Hexagon socket screw with cup point	M8 × 20	5
83	MJ7115.1-09	Adjust screw	45	2
84	MJ7115.1-08	Adjust board	HT150	1
85	MJ7115.1-18	Pulley	A3	1
86	GB119-86	Parallel pins	6 × 45	1
87	MJ7115.1-17	Pressure board	A3	1
88	GB818-85	Cross recessed pan head screws	M5 × 8	3
89		Oil pipe pressure board	A3	2
90	GB70-85	Socket head cap screw	M10 × 14	4
91	MJ7115.1-11	Elevating base	HT150	1
92	MJ7115.1-46	Adjust board	HT150	1
93		Oil separator	PT-6S	1
94		Oiler	LK-8TR	1
95	GB70-85	Socket head cap screw	M6 × 16	3
96	GB93-87	Single coil spring lock washer	6	3

PARTS LIST				
REF No.	PARTS No.	PARTS NAME	MATERIAL & SPEC.	AMT USED
97	GB70-85	Socket head cap screw	M5×10	1
98	GB6170-86	Nut	M12	2
99	MJ7115, 1-49	Limited board	A3	1
100	GB301-84	Thrust bearing	8102	1

MACHINERYHOUSE